

PAPIERSPAVIOT
since 1867

PACK 2000[®]

Concept

PATENTED CONCEPT

Watertight packaging

Environment-friendly packaging

Hygiene - Safety - Conservation

Can be frozen immediately

Pack 2000[®]



The PACK 2000[®] is a concept that ensures your customer : **hygiene, sealing and conservation** of fresh food products. The packaging which can be **immediately frozen**, is also an excellent base for advertising.

Its design based on iron cast components guarantees **long-term resistance**.

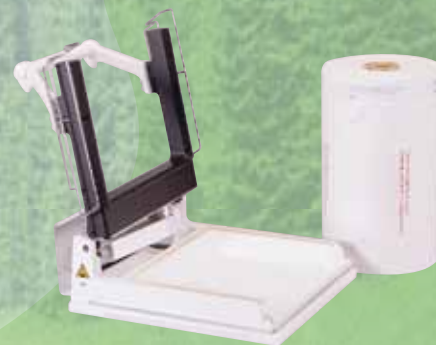

Pack 2000[®] and consumable

Our other brands

EXTRAPAP
BLOND 2000

Thermop[®]

ALPAMER[®] DELI



8, rue du Vercors - ZI Corbas Montmartin 69960 CORBAS - FRANCE

Tel. : 00 33 4 78 20 73 07 - Fax : 00 33 4 78 21 58 79

www.papiers-paviot.fr

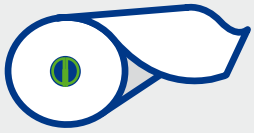

PAPIERSPAVIOT
since 1867

PACK 2000[®]

Concept

PATENTED CONCEPT

Watertight packaging

Hygiene - Safety - Conservation

Can be frozen immediately

DATA SHEET

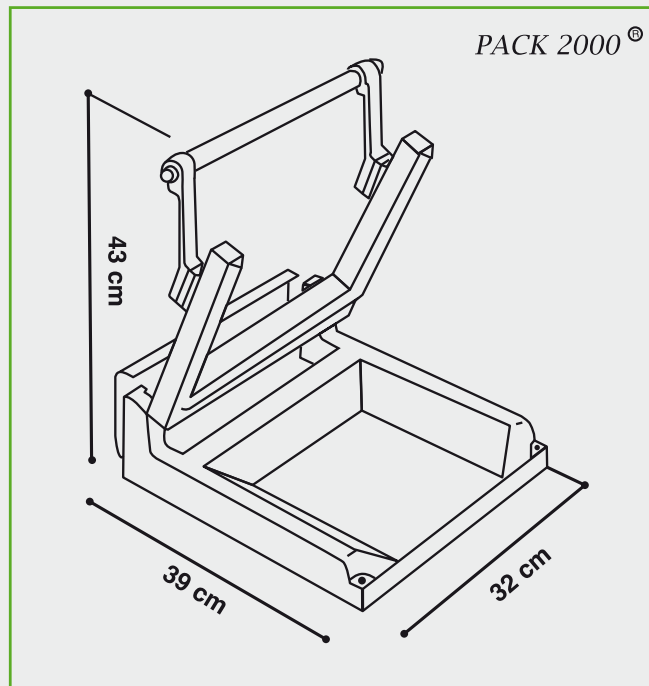

EQUIPMENT complies with European standards
Made in Lyon

The Advantages :

- * **Heavy-duty** : Iron cast parts, components made from aluminium and stainless steel
- * **Reliable** : Parts and labour guaranteed 1 year
LONG LIFETIME GUARANTEED
- * **Easy** : Installation, use, maintenance

The Service :

Installation of equipment, **training**,
and user **monitoring**,
are performed by our **instructor-demonstrators**
(professionals in the field).
After sales service is carried out by our area manager.

Technical characteristics

Power supply	220 V monophase+ground
Power	400 W
Packaging	ALPAMER [®] Thermo Top Paper
Weight	6,5 Kg



PAPIERSPAVIOT
since 1867

8, rue du Vercors - ZI Corbas Montmartin 69960 CORBAS - FRANCE

Tel. : 00 33 4 78 20 73 07 - Fax : 00 33 4 78 21 58 79

www.papiers-paviot.fr